

**Electric winches**

**MOTORBOX<sup>®</sup> 150, 300 and 500 kg**

---

Instruction manual \_\_\_\_\_

**EN**

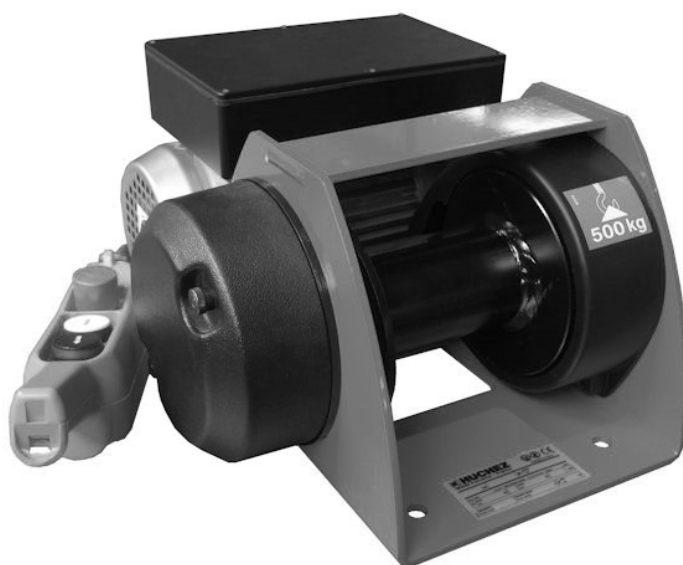

**140-225.13/4**

To ensure the constant improvement of its products, HUCHEZ reserves the right to change the equipment as described below and, in this case, to supply products which differ from the illustrations in this instruction manual.

*All rights reserved*

## Contents

1 - Conditions of use .....	2
2 - Safety instructions .....	3
3 - Warranty .....	4
4 – Reception of the equipment .....	4
5 – Obligatory regulatory checks by the user .....	5
6 – Presentation of the machines .....	5
6.1 - General information	
6.2 - Dimensions	
6.3 – Models available	
6.4- FEM classification	
7 – Handling - Storage .....	8
8 - Installation and set-up.....	9
8.1- Installation	
8.2-Place of installation	
8.3 – Rope outlets	
8.4 – Power supply	
8.4.1 – Electrical connections	
8.4.2 – Connection	
8.5 - Work rope	
9 – Servicing and maintenance .....	14
9.1 -Before switching on	
9.2 – Periodic servicing	
10 – Taking out of use .....	15
11 – Spare parts .....	15
12 – Operating faults.....	16
13 – Declaration of EC conformity .....	17
14 – Annexes .....	19
A – Part references	
. Limit switch MOTORBOX® 150 kg	
. Limit switch MOTORBOX® 300/500 kg	
. MOTORBOX® 150 kg	
. MOTORBOX® 300 kg	
. MOTORBOX® 500 kg	
B – Electrical diagrams	
C - Limit switch adjustment.	
D - Maintenance booklet.	

## 1 - Conditions of use

Users must read the set-up instructions carefully before using the product for the <sup>first</sup> time. These instructions should enable the user to familiarise themselves with the winch and use it to its full capacity. The set-up instructions contain important information about how to use the winch in a safe and correct manner. Compliance with these instructions helps to avoid danger, reduce repair costs, reduce stoppage time and improve the reliability and service life of the winch. The instruction manual must always be available in the place where the winch is being used. In addition to the set-up instructions and regulations concerning the prevention of accidents, the work safety and trade rules in force in each country must also be respected.

This equipment is governed by European regulations and more specifically Directive 2006/42/EC on machinery, EMC Directive 2004/108/EC and LVD 2006/95/EC, as well as the EN 14492/1 standard.

These winches are designed to move loads using a suitable steel rope. They have been designed to perform lifting and pulling operations within the defined load capacity limit and with safety factor 5 (static against sudden failure).

- For use in lifting, the European regulation makes certain equipment obligatory, such as a limit switch system and, for loads of 1,000 kg or more, a load limiter.
- The operator must check that this equipment is present (available as an option from the manufacturer) before using the product for lifting purposes.
- The capacity indicated on the winch corresponds to the maximum capacity of use (MCU); in no event should this capacity be exceeded.
- **THIS WINCH CAN, UNDER NO CIRCUMSTANCES, BE USED TO LIFT PEOPLE.**
- Do not begin moving the load until you have attached it correctly and checked that all personnel are outside the danger zone.
- Before use, the operator must always check that the machine, rope, hook, markings and moorings are in good working order.
- The operator must check that the load is attached in such a way that the winch, the cable and the load place neither the operator nor any other person in danger.
- The winches can be used at ambient temperatures ranging from -10°C to +50°C. Please consult the manufacturer in the event of extreme conditions of use.

Important: In the event of an ambient temperature below 0°C, the brake must be tested to ensure that there are no operating faults resulting from the freezing conditions.

Use of winches requires strict compliance with the accident prevention and safety measures in force in the country.

The data concerning the resistance of the steel rope and its fastenings to heat must be available on request from the manufacturer and must be respected.

- HUCHEZ accepts no liability for the consequences resulting from the use or installation of equipment not provided for in the present instructions or for the consequences of disassembly, modifications or replacement of original parts or components with parts or components from other sources without the written agreement of HUCHEZ.

**YOU MUST ALSO RESPECT THE REGULATIONS APPLICABLE IN YOUR COUNTRY.**

---

## 2 - Safety instructions

Before using the equipment, check that there are no causes of overloading such as: adhesion to the ground, suction, jamming, etc. of the load.

As the operator of the winch, you are responsible for your own safety and the safety of your colleagues in the work area of the machine.

The operator must respect all the following safety information, without exception, concerning the handling and operation of the winch as well as the references to other sections of this instruction manual. Non-compliance with these instructions increases the level of risk.

- Only the people designated by the company are authorised to operate the winch
- Before using the winch for the first time, familiarise yourself with its conditions of use. Read the present instruction manual carefully and in its entirety and perform all the operations described herein one after the other.
- Inform your departmental manager or the safety officer of any malfunction so that the fault can be repaired immediately.
- Respect the directives of the industrial accident prevention organisations such as, in France, the Caisse d'Assurance Retraite et de la Santé au Travail (C.A.R.S.A.T.) and the Health and Safety Committee (HSC) of your company, if one exists.
- You must scrupulously respect the information in the sections concerning the CONDITIONS OF USE (below) and the WORK ROPE (page 10)
- The operator(s) must have an unimpeded view of the load.
- Please ensure that the operator is qualified to operate the machine in the conditions provided for in this manual. This will ensure the safety of both people and the environment.
- Do not lift or transport loads when there are personnel inside the danger zone.
- Do not authorise the personnel to walk under a suspended load.
- Do not leave a load suspended or with the rope taut unsupervised.

In addition to the above instructions, we must warn you against all incorrect use or handling listed below. It is dangerous and prohibited to:

- unwind the drum completely (retain 2 to 3 residual windings).
- pull at an angle.
- swing the load.
- use ropes with a diameter and texture which do not correspond to the specifications in this manual (FEM 1dm – ISO M1).
- use damaged ropes or ropes with splices.
- grab or touch a moving cable or a rotating drum.
- use hooks without a latch, which do not correspond to the loads indicated on the winch or which are in poor condition.
- insert objects into moving parts.
- work on loaded winches or when the rope is taut
- use the winch rope as a towing chain.
- drum on the control box (overheating of the motor and electrical equipment).
- place hands or clothes, etc. in contact with moving parts, in particular the areas where the rope is wound in/out.

---

### **3 - Warranty**

Our electric winches are guaranteed for 1 year from the date of shipment (ex-works). The seller undertakes to repair any operating fault resulting from a fault in the design, execution, components or materials themselves.

The warranty does not cover wear and tear or damage resulting from a lack of regular or periodic maintenance. It does not cover damage resulting from a lack of supervision, incorrect handling or an incorrect use of the machines, in particular overloading, pulling at an angle, under or overvoltage or incorrect connection.

The warranty does not apply to any disassembly, modification or replacement of mechanical or electrical parts undertaken without our agreement or by a non-approved operator. The warranty only applies to the manufacturer's original spare parts. During the warranty period, the seller must replace or repair any parts recognised as faulty after inspection by the qualified and approved department, all free of charge.

The warranty excludes all other services or compensation.

Repairs undertaken within the framework of the warranty are, in principle, performed in the seller's workshops or the workshop of their representative approved by the manufacturer. When the intervention on the equipment occurs outside their workshops, the seller must cover the labour costs related to the disassembly or reassembly of these parts if these operations are performed exclusively by their personnel or their representative approved by the manufacturer. The parts replaced become the property of the seller and must be returned to them at their cost.

In the case of components with a particular relative importance not manufactured by the seller themselves and which carry the brand of specialist manufacturers, the warranty, which may vary according to the manufacturer, is the same as that agreed by this manufacturer.

---

### **4 – Reception of the equipment**

Conduct a visual inspection of the packaging to ensure that it is in good condition.

In the event of an anomaly, issue the usual reserves.

Check that the winch corresponds to your order.

## 5 – Obligatory regulatory checks by the user

This equipment has been designed to be tested:

- In a dynamic situation, with coefficient 1.1
- In a static situation, with coefficient 1.25

The users are required to comply with the standards in force in their country.

With regard to France:

Order of 1<sup>st</sup> March 2004 relating to the verification of lifting machines and accessories:

The modifications to the regulation relating to the use and verification of lifting machines and accessories, which came into effect on 1st April 2005, impose new obligations on all users:

- The suitability inspection which involves checking that the lifting machine is suitable for the work that the user intends to carry out as well as for the risks to which workers are exposed and that the intended operations are compatible with the conditions of use for the machine defined by the manufacturer.
- The assembly and installation inspection, which involves ensuring that the lifting machine is assembled and installed in a safe way in accordance with the manufacturer's instruction manual,
- The general periodic visits, which involve an inspection of the state of preservation and the operating tests.
- The set-up or renewed set-up inspections: in the event of a change in the place of use, the configuration or the conditions of use on the same site; following the disassembly and subsequent reassembly of the lifting machine; after any major replacement, repair or transformation concerning the essential components of the lifting machine; following any accident caused by the failure of an essential component of the lifting machine.
- The maintenance booklet (Order of 2nd March 2004 applicable from 1st April 2005) which must be used to record the maintenance operations carried out in accordance with the recommendations of the manufacturer of the machine as well as any other inspection, maintenance operation, repair, replacement or modification carried out on the machine. For each operation, it is essential to record the date of the work, the names of the people and, where appropriate, the companies which carried out the work, the nature of the operation and, if it is a periodic operation, the frequency. If the operations involve the replacement of certain components of the machine, the references of these components are indicated. The English version of the maintenance booklet for our lifting winches can be downloaded from our website [www.huchez.fr/](http://www.huchez.fr/) uk under the heading "After sales services". A copy is however proposed in the annexes of this manual.

The inspections must be carried out in accordance with a protocol and are intended to ensure preventive maintenance aimed at detecting any damage or defectiveness liable to result in a danger.

## 6 – Presentation of the machines

### 6.1 - General information

These winches are available in 150 kg, 300 kg and 500 kg versions, with limit switch. They are available in versions with direct control or with low voltage control. They are intended for an occasional use for pulling or lifting loads.

- . Rigid steel structure
- . Mechanically welded steel drum with wide flanges for safe and sound fastening of the rope.
- . 230 volt, 50 Hz single-phase lifting-type self-braking motor. P = 0.25 kW (MOTORBOX® 150 kg) or P=0.37 kW (MOTORBOX® 300/500 kg) – Insulation class F – IP 44 (MOTORBOX® 150 kg) or IP 54 (MOTORBOX® 300/500 kg).
- . The FEM category is 1 dm (ISO: M1).
- . 230 V single-phase control box. – IP 65 double insulation.
- . Emergency stop as standard

## 6.2 - Dimensions

### Direct control model (CD)

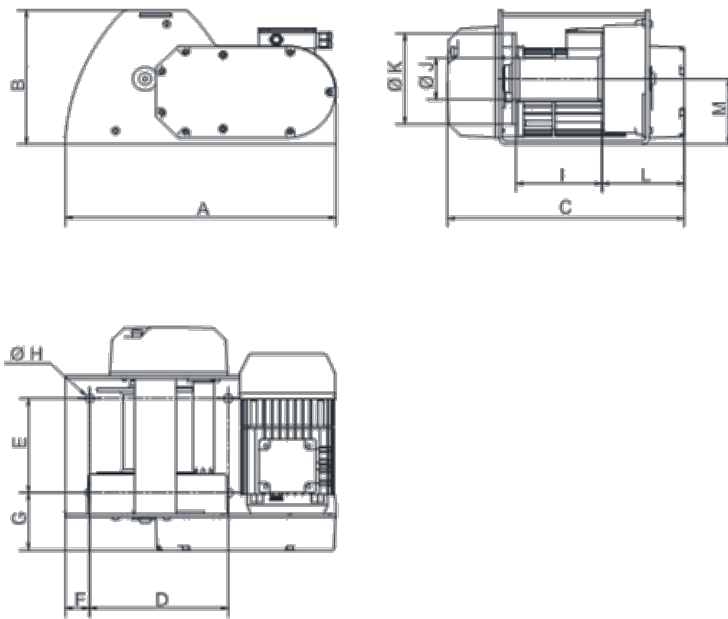

### Low voltage model (BT)

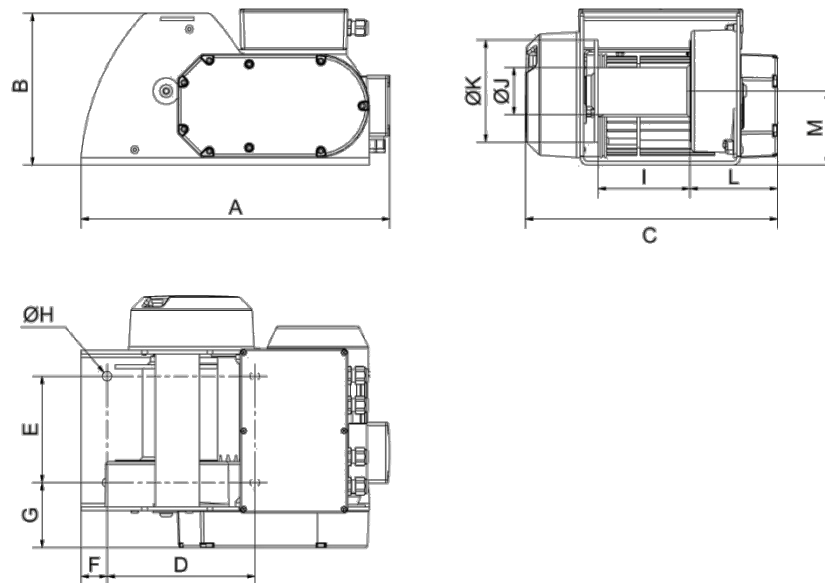

(mm)	MOTORBOX 150		MOTORBOX 300		MOTORBOX 500	
	CD	BT	CD	BT	CD	BT
A	310	327	390	418	390	418
B	281	281	341	341	341	341
C	179	206	205	212	205	212
D	154	154	200	200	200	200
E	114	114	144	144	144	144
F	15	15	35	35	35	35
G	68	68	88	88	88	88
Ø H	9	9	13	13	13	13
I	105	105	124	124	124	124
Ø J	54	54	63.5	63.5	63.5	63.5
Ø K	122	122	138	138	138	138
L	76	76	118.5	118.5	118.5	118.5
M	79	79	100	100	100	100

Cable outlet range Motorbox 150 CD

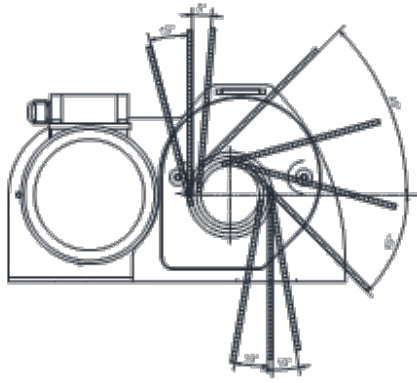

Cable outlet range Motorbox 150 BT

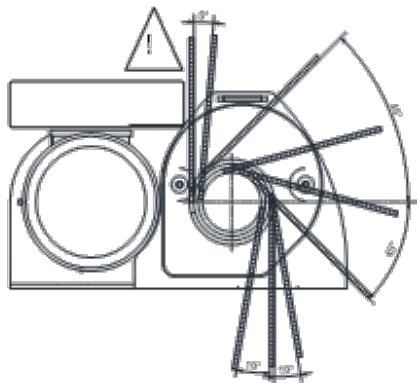

Cable outlet range Motorbox 300/500 CD &amp; BT

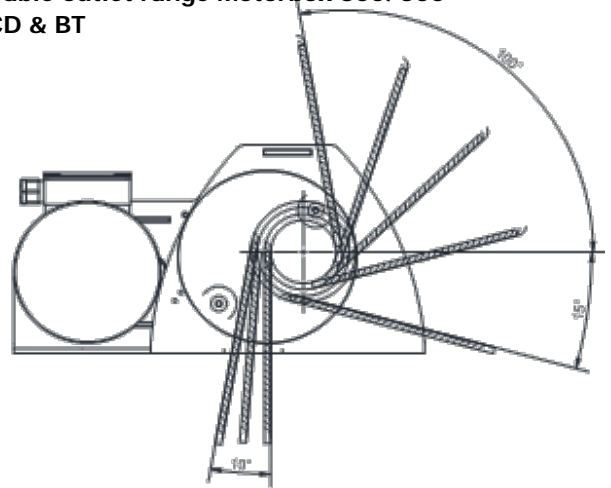

### 6.3 – Models available

References	MOTORBOX®	150 CD 6	150 BT 6	300 CD 5	300 BT 5	500 CD 3	500 BT 3
<b>Force on the 1st layer kg</b>		<b>150</b>	<b>150</b>	<b>300</b>	<b>300</b>	<b>500</b>	<b>500</b>
Force on the upper layer kg		150	150	300	300	500	500
No. of layers		3	3	3	3	3	3
Rope cap. on the 1st layer m *		4	4	4	4	4	4
Rope cap. on the upper layer m *		15	15	16	16	13,5	13,5
RopeØ mm		4	4	5	5	6	6
Speed on the 1st layer m/min.		5,5	5,5	4,6	4,6	2,6	2,6
Speed on the upper layer m/min.		7	7	6	6	3,5	3,5
FEM		1Dm	1Dm	1Dm	1Dm	1Dm	1Dm
Motor kW		0,25	0,25	0,37	0,37	0,37	0,37
Power supply		1Ph - 230 V	1Ph - 230 V	1Ph - 230 V	1Ph - 230 V	1Ph - 230 V	1Ph - 230 V
Weight (bare winch, without rope) kg		14	16	27	29	27	29

**Important:** the rope diameter indicated above corresponds to rope established in the FEM 1 Dm / ISO M1 classification. It also corresponds to the capacity on the last layer.

**Important:** it must be ensured that the cable strength coefficient matches the load lifted (FEM 1 Dm / ISO M1)

## 6.4- FEM classification

There are eight groups of mechanisms:

FEM	1 Dm	1 Cm	1 Bm	1 Am	2m	3m	4m	5m
ISO	M 1	M 2	M 3	M 4	M 5	M 6	M 7	M 8

To determine the group for a lifting machine, winch or hoist, three essential parameters must be considered:

### The maximum load to be lifted

Including the weight of the rope and any lifting accessories present (hook etc.), except if they have a total weight less than or equal to 5% of the load to be lifted.

### The usage rate

Indicates the extent to which the lifting machine is used at maximum load or with a reduced load. There are four different usage rates:

Light	Lifting machines rarely subject to maximum load and regularly used for very light loads.	$k \leq 0.5$
Medium	Lifting machines quite often subject to maximum load and regularly used for light loads.	$0.5 < k \leq 0.63$
Heavy	Lifting machines often subject to maximum load and regularly used for medium loads.	$0.63 < k \leq 0.8$
Very heavy	Lifting machines regularly subject to loads close to the maximum load.	$0.8 < k \leq 1$

For an exact classification, it is preferable to calculate the average cubic value using the following formula:  $k = \sqrt[3]{(\beta_1 + \gamma)^3 \cdot t_1 + (\beta_2 + \gamma)^3 \cdot t_2 + \dots + \gamma^3 \cdot t_{\Delta}}$   
where:

$\beta = \frac{\text{payload or partial load}}{\text{rated capacity}}$	$t = \frac{\text{operating time with payload or partial load} + \text{dead weight}}{\text{total operating time}}$
$\gamma = \frac{\text{dead weight}}{\text{maximum load}}$	$t_{\Delta} = \frac{\text{operating time with dead weight only}}{\text{total operating time}}$

## FEM classification

Usage rate	MOTORBOX 150 - 300 - 500			
	Average operating time per day in hours.			
	7'30''	15'	30'	1 h
Light	1 Dm	1 Dm	1 Dm	1 Cm
Medium	1 Dm	1 Dm	1 Cm	1 Bm
Heavy	1 Dm	1 Cm	1 Bm	1 Am
Very heavy	1 Cm	1 Bm	1 Am	2m

## 7 – Handling - Storage

Given their weight MOTORBOX winches require no special handling equipment.

When stored, these winches must be protected from bad weather in a clean and dry place at a temperature between -10°C and +50°C.



## 8 - Installation and set-up

### 8.1- Installation

The service life of a winch depends on its installation and set-up.

It is essential that you read this manual carefully before installing, using and servicing your machine.

Any use which contravenes our instructions may create risks. In this case, the manufacturer cannot accept any liability.

- Do not use this machine before having read and understood the instruction manual in its entirety
- Always keep the manual close to the machine, available to the operator and the maintenance officer
- Comply and ensure compliance with the safety rules

Connect to the power supply (see 8.4 Power supply)

Check the rope and hook

While ready to press the emergency stop button at all times and with no load attached, check that the movement of the hook corresponds to the direction of the arrows indicated on the control unit.

Check that the brake works: with a nominal load attached, lift the load and lower it again or, in the case of pulling, pull this load.

Check that the limit switch works.

The winch has been subjected to the dynamic and static tests in the factory (cf. Test record).

### 8.2-Place of installation

These winches must be installed and bolted to a flat, solid and secure surface capable of bearing the loads to which it will be subjected. An unsuitable installation site may lead to serious accidents.

To assess the suitability of the place of installation and its resistance to loads, you must take into account any possible overloading, the weight of the winch itself and the weight of the options and/or accessories fitted to it, including all dynamic forces. The winch user is responsible for determining the place of installation. If in doubt with regard to the suitability of a place of installation, contact a civil engineer or a statics specialist.

Tighten the clamping bolts correctly

Models	Bolt / nut	Grade 8.8 bolt / nut tightening torque Nm
MOTORBOX 150 kg	M8	27
MOTORBOX 300/500 kg	M12	90

### 8.3 – Rope outlets

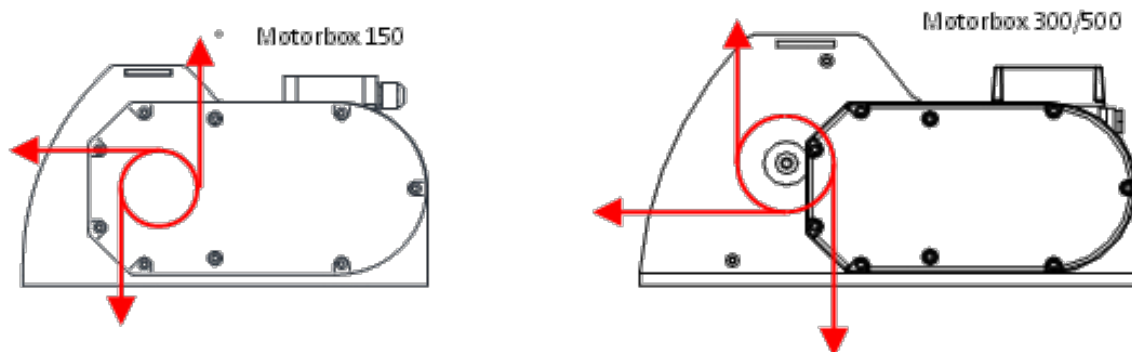

\* Note: very limited outlet on the 150 low voltage (BT) version

## 8.4 – Power supply

Before undertaking any operation on the electrical assembly, check that the power supply to the machine is off.

A disconnecting switch must be placed no more than 10 metres from the place of use.

Very important: the winch will provide full power only if the motor is supplied by a cable with fully suitable cross-section.

Provide personal protection in front of the winch.

### 8.4.1 – Electrical connections

The power supply cable, the protective fuses and the main disconnecting switch (see wiring diagram) must be provided by the customer.

Check that the power supply network is right for the machine.

Check the type of current; there must not be more than about 5% deviation from the rated voltage.

Neutralise power sources.

Check that the main power supply switch on the winch is in the off position.

Do not connect the power supply cable to the machine using connection terminals (split fittings etc.).

Do not use a cable with a smaller cross-section to supply power to the machine.

Never "shunt" the disconnecting switches, electrical switches, prevention or limitation equipment.

Never block, adjust or remove switches or end stops in order to go beyond the levels that they allow.

A disconnecting switch must be placed no more than 10 metres from the place of use.

Recommended rope section:

VOLTAGE	TYPE	Length of supply cable	
		10 m max.	30 m max.
230 V single phase	2 + T	1.5 mm <sup>2</sup>	2.5 mm <sup>2</sup>

### 8.4.2 – Connection

Connect the power supply using the single-phase or three-phase male connector supplied and using about 0.5 m of power supply cable.

Check that the winch works (direction of rotation)

## 8.5 - Work rope

Reminder: Check the maximum capacity of the winch

Very important:

The safety regulations require that 2 to 3 loops of rope always be left on the drum.

To comply with the legislation, the rope diameter must not exceed the recommended diameter.

If the rope and the hook used were not supplied with the machine by the manufacturer, check that they guarantee a level of safety corresponding to table § 6.4.

The service life of the steel ropes used on the winch depends on a number of factors, including the form of the work cycles (lifting height, lifting speed, number and type of deviations, etc.) and the operating mode (number of coil layers, distribution of the work cycles over the length of the steel rope, etc.). The service life of steel ropes is therefore subject to considerable variation depending on these factors.

Please remember that rope replacement must be done using equipment with the same specifications as the original rope.

This replacement must be recorded in the maintenance booklet.

**IMPORTANT:** Even if the rope was supplied with the winch, it was not tautened during assembly. The user must tighten it using a minimum force of between 1% and 2% of the rope's breaking load.

**Measuring the rope diameter using sleeve callipers:**

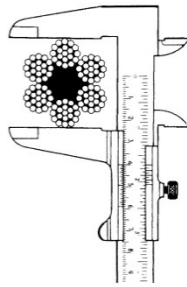

**Correct measurement**

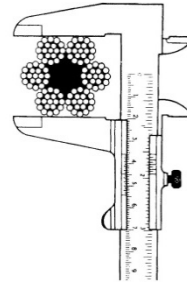

**Incorrect measurement**

**Handling steel ropes**

- Always use suitable protective gloves when handling steel ropes
- Never use a rope with faults such as:
  - ✓ An unacceptable number of broken strands
  - ✓ Basket distortions
  - ✓ Broken bird-caging
  - ✓ Flattening
  - ✓ Constrictions
  - ✓ Strand extrusions
  - ✓ Broken rope cores
  - ✓ Slack strands
  - ✓ Bends or loops
- Always check the level of wear of the rope before use
- Never use steel ropes as loops
- Never expose steel ropes to angular or sharp edges



**Unwinding the rope from its reel:**

**CORRECT:**

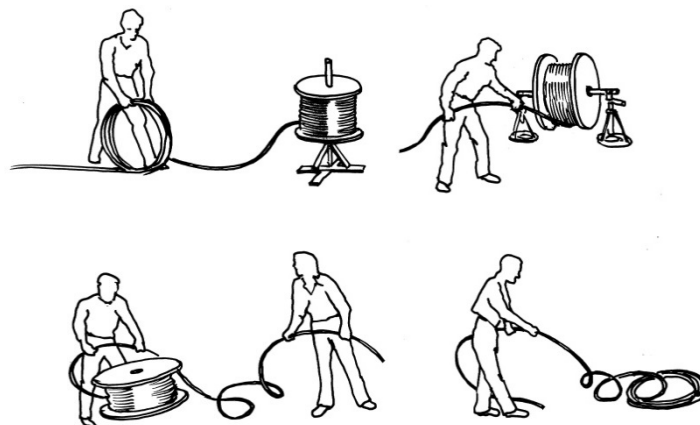

**INCORRECT**

## Fastening the rope

Refer to the photos below.

### MOTORBOX 150 kg

- Untighten the 2 screws
- Insert the end of the rope through the drum flange and under the cable clamp.
- Tighten the 2 screws

**The rope should never form a loop.**

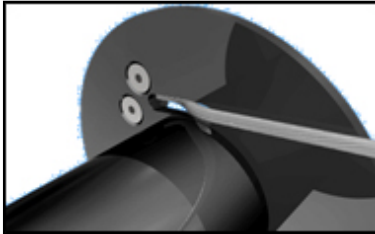

### MOTORBOX 300/500 kg

- If necessary, open the limit switch cover
- Untighten the nuts
- Insert the end of the rope through the rope clamp and into the drum
- Tighten the screws
- Check that the rope is securely clamped
- Reassemble the limit switch cover

**The rope should never form a loop.**

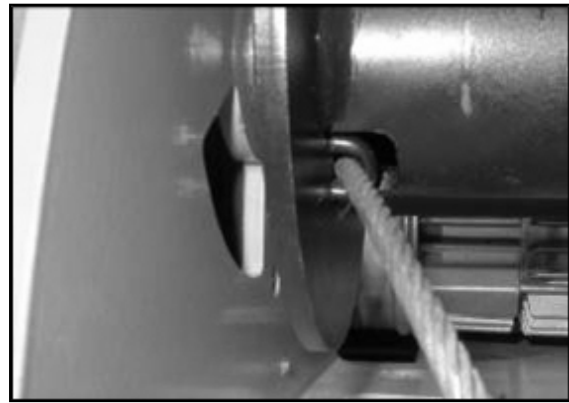

## Winding the rope on the drum

To do this, tauten the rope and wind it with joined strands onto the drum.

**Reminder:** the maximum capacity of these winches is 15 m of rope with a diameter of 4 mm, 16 m of rope with a 5 mm diameter or 13.5 m of rope with a 6 mm diameter depending on the models.

**Very important:** The safety regulations require that 3 loops of rope always be left on the drum. If the rope and the hook used were not supplied by the manufacturer with the machine, check that they guarantee a level of safety corresponding to coefficient 5.

The first layer must be wound in a compact manner and under tension. Take a mallet or a block of wood and knock the turns against one another; not too hard to prevent the strands from overlapping one another, but tightly enough to prevent the rope from moving on the drum. If the first layer is wound too loose, the next layer will form a space in the first layer that will result in an open area. If the first layer is too tight, the subsequent layers will not have enough space between turns.

In any case, the first layer and all the other layers must be wound onto the drum with enough pre-tension (5-10 % of the MWL of the rope). If the rope is wound without any tension, it will suffer from crushing and premature flattening caused by the loaded upper layers.

Even if the first layer is wound correctly during installation, it will expand a little while in service. When the first layer expands (loss of pre-tension) the initial procedure **MUST** be performed at regular intervals.

Otherwise, the "hard" turns will severely crush the base layers.

Whatever you do, **DO NOT** pass the rope through a clamping mechanism. For example, two blocks of wood screwed together. **THIS WILL CAUSE IRREPARABLE DAMAGE TO THE ROPE!**

**It is important** to respect the indication below; if the rope start on the winch is at the bottom, respect the same principle. Not respecting this precaution will damage your rope irretrievably and it will become extremely dangerous.

Check the direction of cable winding according to the motor connection.

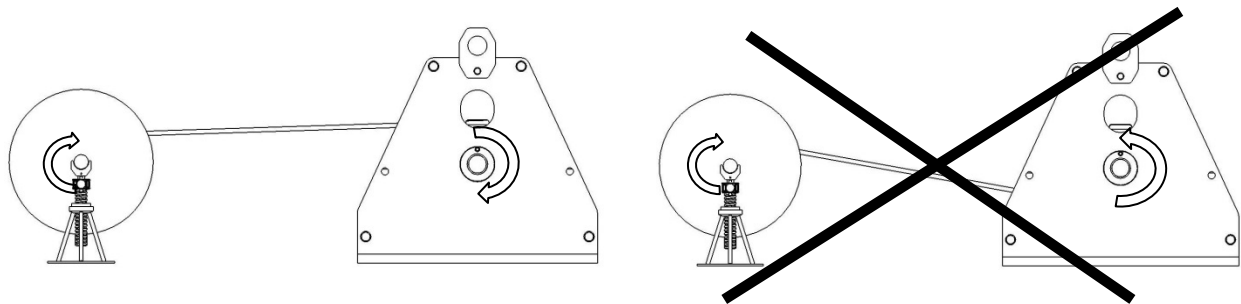

Right-hand rope  
Wind from the left towards the right

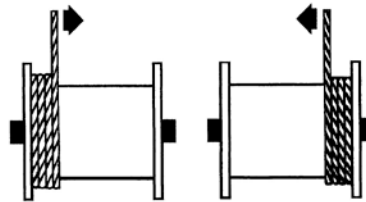

Left-hand rope  
Wind from the right towards the left

Right-hand rope  
Wind from the right towards the left

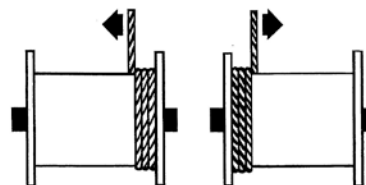

Left-hand rope  
Wind from the left towards the right

**Principle of reeving:**

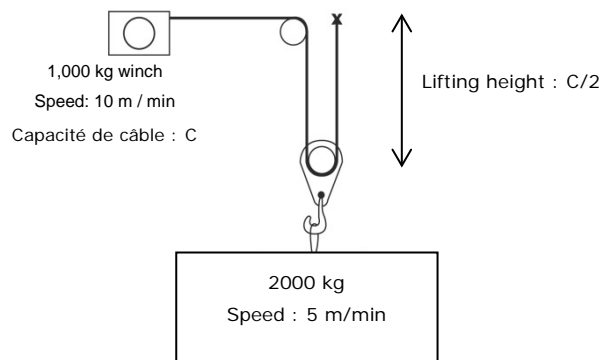

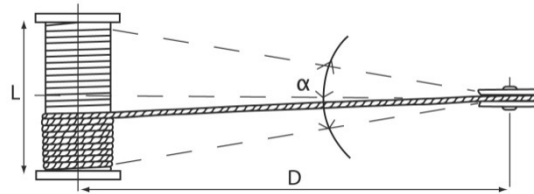

Smooth drum:  $\alpha = \text{max. } 1.5^\circ$   
 Grooved drum:  $\alpha = \text{max. } 2^\circ$   
 $D = 20 \text{ times } L$

## 9 – Servicing and maintenance

### 9.1 -Before switching on

Check:

- The electrical connections are in good working order.
- The rope is correctly fastened to the drum.
- The exterior appearance of the winch.

### 9.2 – Periodic servicing

#### Lubrication

See also chapter 5: Obligatory regulatory checks by the user

**Every 6 months**, check the lubrication: all teeth must be lubricated.

**Every year**, relubricate.

The reducer is lubricated using RENOLIT CXI 2 (FUCHS) grease.

#### Very important:

In the event of a change in the type of grease, contact our after-sales service.

**When the winch has done 50 hours**, it should preferably be serviced by the seller.

**When the winch has done 100 hours**, it **must be** serviced by the seller.

#### Winches

Respect the following instructions, in particular if your winch is used in a large number of different locations or in a particularly dirty and damp environment:

Remove most of the dirt from the winch.

Always store the winch in a dry place

#### Ropes

The ropes must be cleaned and greased regularly using a special grease which penetrates to the rope core.

Only use appropriate and harmless cleaning products for all the components of the rope, including the core.

If lubrication is impossible for reasons linked to use, the service life of the rope will be reduced considerably and increased monitoring of the rope will therefore be necessary.

The ropes must be checked visually every day.

#### Hooks

Check the hook and its safety latch

If the rope and hook are not supplied by the manufacturer, check that the parts used guarantee a level of safety corresponding to table §4.4.

Check the fastening points of the reeving on a regular basis.

**Servicing and maintenance operations on the winch and rope must be carried out without any load on the winch.**

**Brake**

The brake is located at the end of the motor.

## . Operating principle:

When the motor is started, the internal magnetic field opens the brake by lifting the conical plate from the friction surface at the bottom of the motor.

When the motor is stopped, the magnetic field disappears. The central spring closes the brake again by bringing the conical panel back into contact with the motor's rear flange.

## . Adjusting the braking torque (only for MOTORBOX 300 and 500 kg)

The braking torque is not adjustable on the MOTORBOX 150 kg.

Remove the cap ⑤ on the fan cover.

Gradually turn the self-locking nut⑥:

- . clockwise to reduce the braking torque
- . anti-clockwise to increase the torque

## . Adjusting the air gap (only for MOTORBOX 300 and 500 kg)

The air gap is not adjustable on the MOTORBOX 150 kg.

The air gap ⑦ must be adjusted in the event of excessive wear of the friction lining (min. 0.6 mm/max. 0.8 mm).

Remove the cover ① and the fan ②.

Loosen the three screws by a few turns ③.

Turn the ring nut ④ anti-clockwise ( $30^\circ \approx 0.12 \text{ mm}$ ) to reduce the air gap ⑦.

Tighten the three screws ③.

Reposition the fan and its cover.

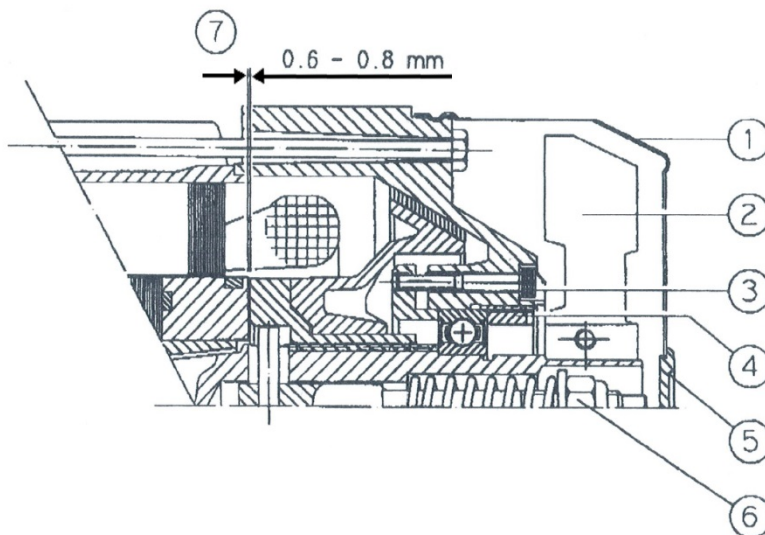
Key:

- ① Cover
- ② Fan
- ③ Screw
- ④ Ring nut
- ⑤ Cap
- ⑥ Self-locking nut
- ⑦ Air gap

**10 – Taking out of use**

If the equipment is in a state of disrepair likely to give rise to risks, the user is obliged to ensure that this equipment is eliminated, i.e.: prevented from operating and possibly disassembly.

**11 – Spare parts**

If, during maintenance operations, you notice that certain parts of your winch need to be replaced, use HUCHEZ original parts only.

For all spare parts orders, please indicate the following specifications on your order

- The type and capacity of the winch (indicated on the nameplate).
- The serial number and year of manufacture (indicated on the nameplate).
- The number or designation of the desired parts (exploded view).

## 12 – Operating faults

Fault	Possible cause	Solution
Motor does not start.	Power supply cut.	Check and correct the problem. Check the emergency stop.
	Brake not released	See "brake fault"
	Limit switch engaged.	Check the limit switch.
Motor does not start or starts with difficulty.	The voltage or frequency varies considerably compared to the setting when starting.	Improve the mains conditions. Check the cable sections.
Motor revs and absorbs a great deal of power.	Brake not released.	See "brake fault".
	Faulty winding.	Take the motor to an approved workshop for repair.
Circuit breaker activated immediately.	Short circuit in the power supply cables.	Eliminate the short circuit.
	Short circuit in the motor.	Have the fault corrected in an approved workshop.
	Power supply cables incorrectly connected.	Correct the connection.
	Motor earth fault.	Have the fault corrected in an approved workshop.
Speed greatly reduced when loaded.	Voltage drop.	Increase the power supply cable section.
Motor too hot (temperature measurement)	Insufficient ventilation.	Clear the ventilation lanes.
	Ambient temperature too high.	Respect the authorised temperature range.
	Circuit breaker activated.	Bad contact in the relays.
	Service factor exceeded (S1 to S10, DIN 57530), e.g. because start speed is too high.	Adapt the service factor to the prescribed conditions; if necessary, call a specialist to determine the type of motor.
Drive system too noisy.	Rotating parts vibrate.	Check the balances, eliminate the cause of the vibrations.
	Foreign bodies in the ventilation lanes.	Clean the ventilation lanes.
Brake not released.	Max. air gap exceeded due to worn lagging.	Adjust the air gap (MOTORBOX 300/500 kg)(see 9.2).
		Change the motor (MOTORBOX 150 kg)
Motor does not brake.	Incorrect air gap.	Adjust the air gap (MOTORBOX 300/500 kg)(see 9.2).
	Brake lagging totally worn.	Change the motor.



## 13 – Declaration of EC conformity

CE



**DECLARATION OF CONFORMITY**

F03.31.1 - UK *Electric winch – MOTORBOX - Tirlev*  
PRIMO – TRBoxter - TRB - TRB VV - TRC  
INDUSTRIA – TT -TE - TEL – PL - Engineering

We hereby declare that the design and manufacture of the machinery referred to below comply with the relevant requirements of Directive 2006/42/CE on Machinery.  
Moreover, we hereby declare that the machinery complies with the following Directives:

- Directive CEM 2000/108/CE
- Directive BT 2006/95/CE

The machinery's technical file has been put together by the signatory of this declaration.  
This declaration shall become null and void in the event it is changed or if any item is added without our prior consent.  
Moreover, this declaration shall become null and void if the machinery is not used in accordance with its instructions for use and if it is not inspected regularly.

Type of device: **Electric winch**

Model:

Force:

Serial n°:

Fuñcion:  Hoisting or hauling equipment  
 Hauling only

Harmonised standard(s) used, notably: EN 14492-1  
Quality assurance: ISO 9001 (certificate registration n°: FQA 9911492)

Equipment delivered:  with cable  with hook  
 without cable  without hook  
*Important: these items must comply strictly with the specifications indicated on the manufacturer's plate affixed to the winch and the instructions for use, and they must be supplied by professionals specialized in their use.*

with limit switch  with load-limiting device  
1000+ kg  
 without limit switch  without load-limiting device  
*For hauling only*

and with instructions for use.

Issued in Ferrières on:

**Antoine Huchez,**  
*President*

[www.huchez.fr](http://www.huchez.fr)

HUCHEZ S.A.S  
Place de l'Eglise  
60200 Ferrières (France)

Tel.: +33 (0)3 44 51 11 33  
Fax: +33 (0)3 44 51 13 15  
contact@huchez.fr

S.A.S. with a capital of 4500,000  
RC Douvres 508 020 482  
APE 2822 Z  
VAT FR 80 528 020 482



---

## 14 – Annexes

### A – Part references

- . Limit switch MOTORBOX 150 kg
- . Limit switch MOTORBOX 300/500 kg
- . MOTORBOX<sup>®</sup> 150 kg
- . MOTORBOX<sup>®</sup> 300 kg
- . MOTORBOX<sup>®</sup> 500 kg

### B – Electrical diagrams

### C - Limit switch adjustment

### D – Booklet maintenance.

# A - Part references

## LIMIT SWITCH (SE n°24 on MOTORBOX 150 kg BT/CD)

Article	Qty	Part number	Description	Article	Qty	Part number	Description
1	2	2996	M3 x 25 MF spacer stud	15	3	23212	48-tooth sprocket wheel
2	2	3384	Tie	16	1	23213	20-tooth sprocket wheel
3	2	3683	contactor	17	2	23214	45-tooth sprocket wheel
4	2	4909	Captive nut	18	1	23215R	Red limit switch finger
5	1	13020	Locknut M10	19	1	23215V	Green limit switch finger
6	3	13057	TH M6x12 screw (DC model)	20	1	23237	limit switch cover
	2	13057	TH M6x12 screw (LV model)	21	1	23291	Limit switch offset shaft
	1	13058	TH M6x16 screw (LV model)	22	1	23292	Limit switch finger support
7	1	13209	Washer MU 6	23	2	23293	Stop washer
8	1	13306	Washer MU 10	24	1	24265	Limit switch shaft
9	2	13365	TRUARC 8-9 ring	25	1	24297	Limit switch mounting plate
10	1	13640	TBHC M6x16 screw	26	1	24298	Limit switch offset 23-tooth sprocket wheel
11	2	13693	∅15x20x2 curved washer	27	1	24299	Limit switch Wheel spacer
12	2	13694	CHC M3x25 screw				
13	2	13695	TRUARC 5-6 ring				
14	3	23211	17-tooth sprocket wheel				

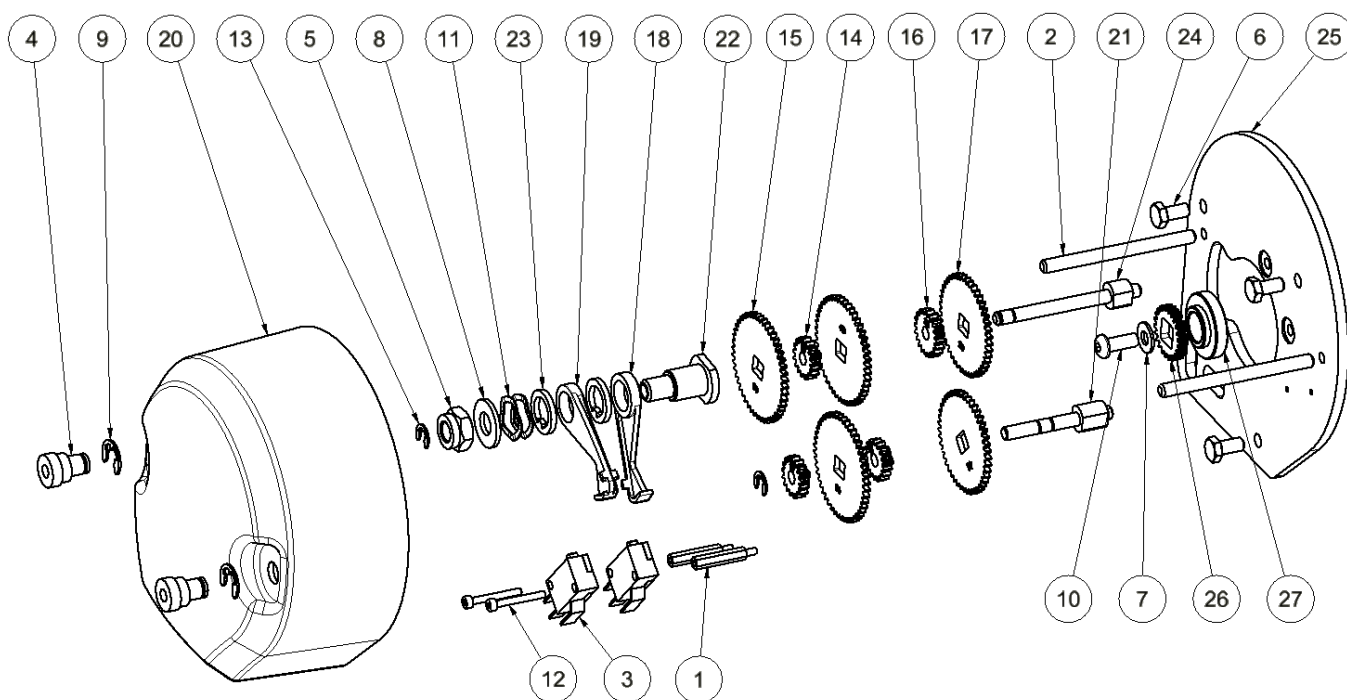

## LIMIT SWITCH (SE n° 39 on MOTORBOX 300/500 kg BT/CD)

Article	Qty	Part number	Description	Article	Qty	Part number	Description
1	2	2965	M3 x 30 MF spacer stud	14	6	23211	M1 17-tooth sprocket wheel
2	2	3683	Contacteur	15	7	23212	M1 48-tooth sprocket wheel
3	2	4909	Captive nut	16	2	23214	M1 45-tooth sprocket wheel
4	2	13010	NF E 24032 M6 nut	17	1	23215R	Red limit switch finger
5	3	13122	M5x12 CHC screw	18	1	23215V	Green limit switch finger
6	1	13123	M5x16 CHC screw	19	1	23291	Limit switch offset shaft
7	1	13207	LU 5 washer	20	1	23292	Limit switch finger support
8	1	13306	Washer M Ø10	21	2	23293	Stop washer
9	2	13365	7144.9E TRUARC ring	22	2	23435	Tie
10	2	13693	15x20x2 curved washer	23	1	23449	TRB 2 limit switch cover
11	2	13694	M3x25 CHC screw	24	1	24252	Limit switch mounting plate
12	2	13695	TRUARC 5-6 ring	25	1	24265	Limit switch shaft
13	1	13816	M10 locked bottom nut				

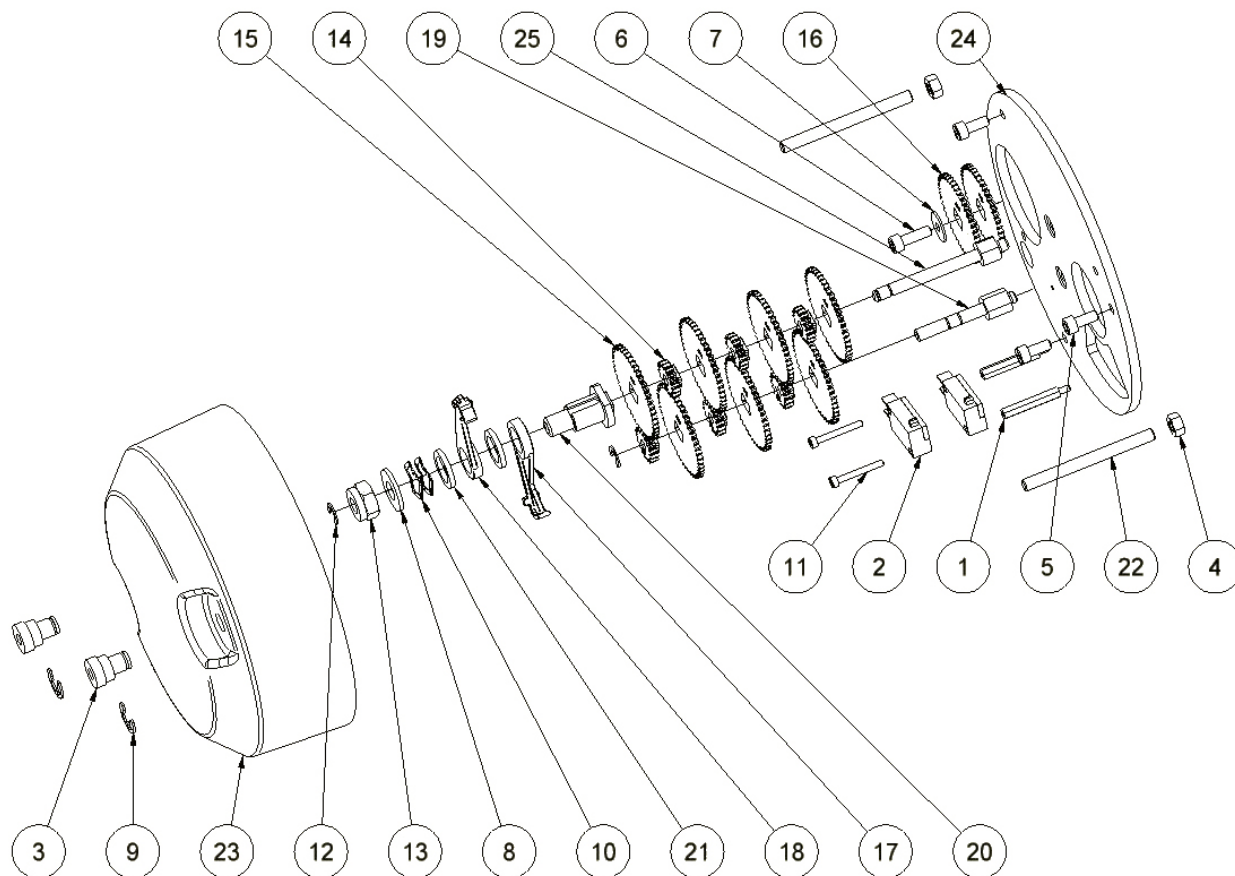

**MOTORBOX 150 kg CD**

Article	Qty	Part number	Description	Article	Qty	Part number	Description
1	1	2510	6004 2RS NR bearing	13	1	24280	0.25 kW single-phase motor brake
2	4	2964	6003 2RS RN bearing	14	1	24281	Motorbox 150 frame
3	1	3970	6005 2RS RN bearing	15	1	24282	Motorbox 150 drum
4	4	13125	CHC M5x25 screw	16	1	24289	Drum shaft
5	9	13129	CHC M5x50 screw	17	1	24290	Motor flange
6	1	13228	8 x 7 x 20 FA key	18	1	24291	Reduction gear reinforcing metal plate
7	1	13232	6 x 6 x 12 FB key	19	4	24292	Frame spacer
8	2	13233	6 x 6 x 12 FC key	20	1	24293	46-tooth wheel
9	1	13643	TBHC M8x20 screw	21	2	24294	19-tooth sprocket wheel
10	8	13686	TBHC M6x12 screw	22	2	24295	55-tooth wheel
11	1	24250	Reduction gear cover	23	1	24296	Compression washer
12	1	24260	Set ring	24	1		SE limit switch

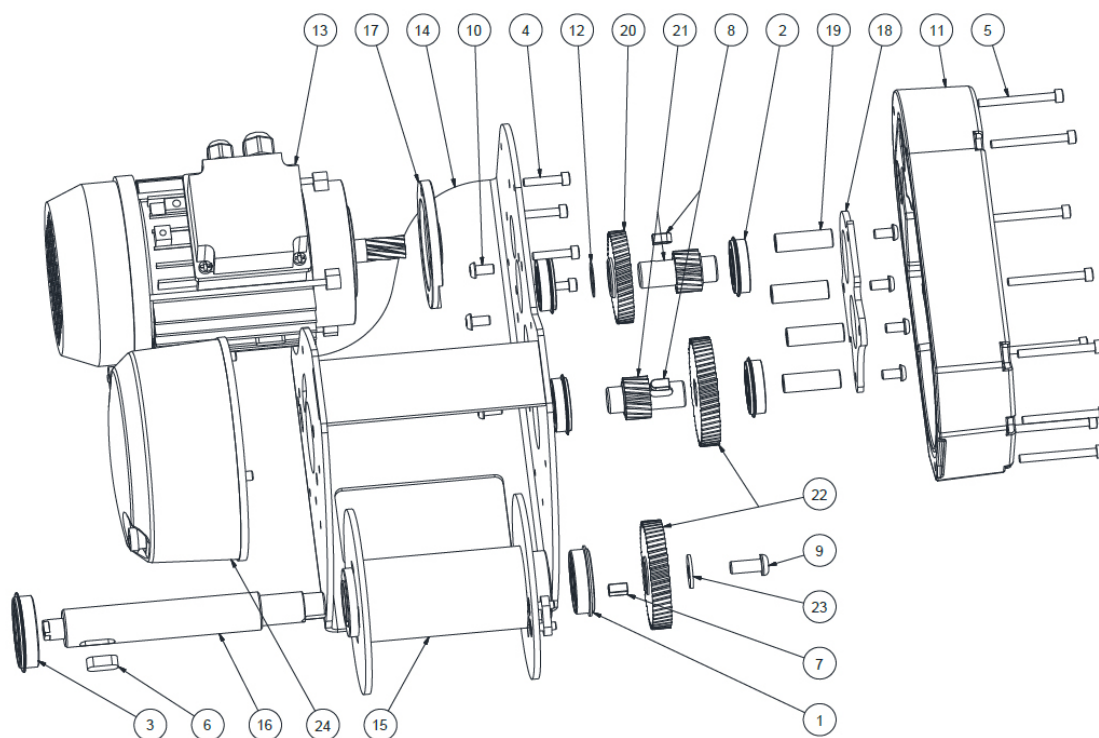

**MOTORBOX 150 kg BT**

Article	Qty	Part number	Description	Article	Qty	Part number	Description
1	1	2510	Bearing 6004 2RS NR	18	1	24291	Protected metal reduction system
2	4	2964	Bearing 6003 2RS RN	19	4	24292	Frame spacer
3	1	3970	Bearing 6005 2RS RN	20	1	24293	46-tooth wheel
4	4	13125	Screw CHC M5x25	21	2	24294	19-tooth sprocket wheel
5	7	13129	Screw CHC M5x50	22	2	24295	55-tooth wheel
6	1	13228	Pin 8 x 7 x 20 FA	23	1	24296	Clamping washer
7	1	13232	Pin 6 x 6 x 12 FB	24	1		SE limit switch
8	2	13233	Pin 6 x 6 x 12 FC	25	1	2014	Small charge LV
9	1	13643	Screw TBHC M8x20 ZN	26	4	2405	Cable gland M16 black
10	8	13686	Screw TB HC M6x12	27	4	13009	Nut M5
11	1	24250	Reducer cover	28	4	13122	Screw CHC M5x12
12	1	24260	Stop washer	29	8	13208	Washer MU 5
13	1	24280	0.25 kW single-phase motor break	30	2	13270	Screw CHC M5x55
14	1	24281	Frame	31	6	13271	Support CI 8mm
15	1	24282	Drum	32	1	24749	Casing
16	1	24289	Drum shaft	33	1	64142	Casing bracing plate
17	1	24290	Motor flange				

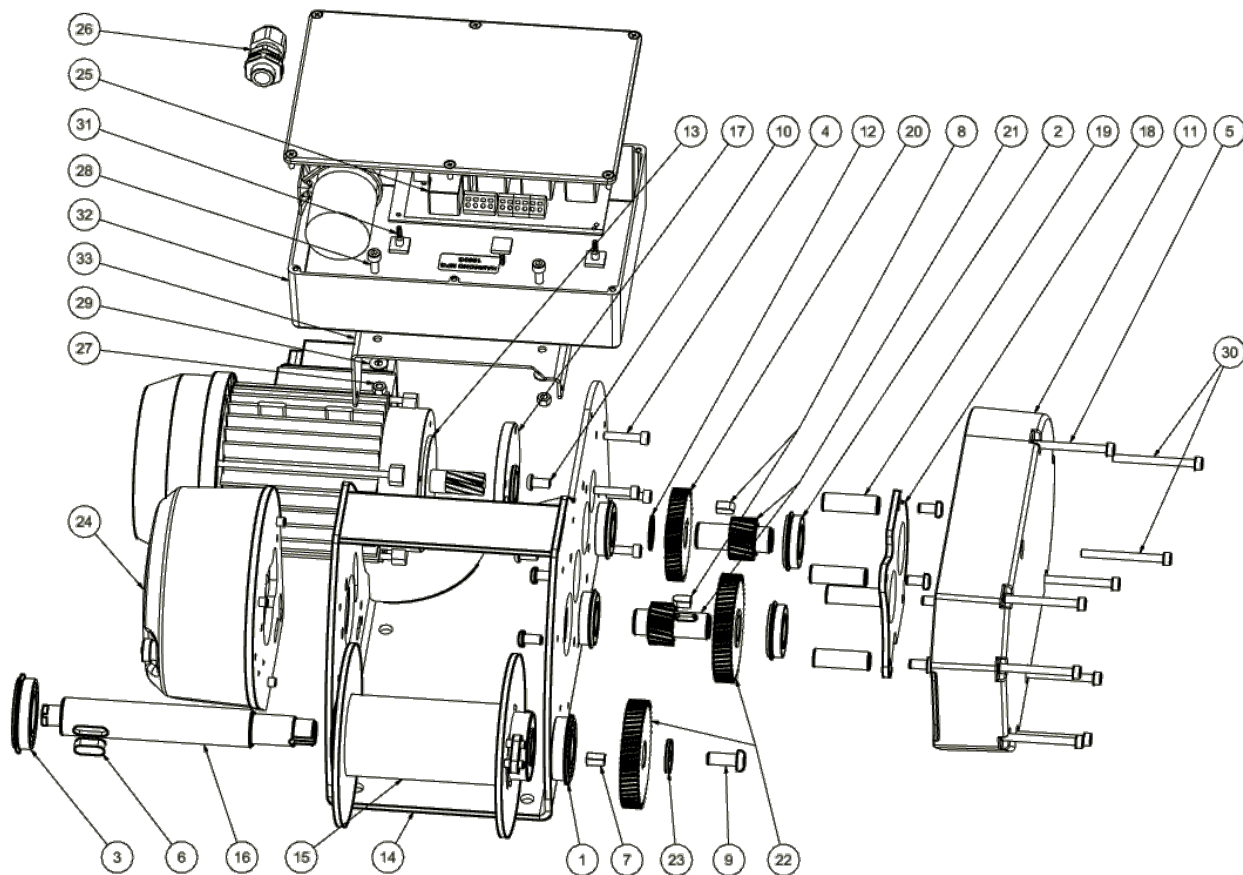

## MOTORBOX 300 kg CD

Art.	Qty	Part number	Description	Art.	Qty	Part number	Description
1	1	2510	6004 2RS NR bearing	21	1	23777	Joint foam
2	2	2776	QFM 2528-21 ring	22	1	24250	Reduction gear cover
3	1	2889	QSM 2528-25 ring	23	1	24251	Motorbox frame
4	2	2964	6003 2RS RN bearing	24	1	24253	8-tooth pinion shaft
5	1	3970	6005 2RS RN bearing	25	1	24254	M1.25 18-tooth sprocket wheel
6	2	13009	M5 nut	26	1	24255	M1.25 71-tooth wheel
7	1	13047	25x1.2 ext. retaining ring	27	1	24256	Reinforcing metal closure plate
8	4	13122	M5x12 CHC screw	28	1	24267	M1.25 29-tooth sprocket wheel
9	1	13123	M5x16 CHC screw	29	1	24268	M1.25 69-tooth wheel
10	9	13129	M5x50 CHC screw	30	1	24259	Bearing spacer
11	2	13207	LU 5 washer	31	1	24260	Set ring
12	2	13640	M6x16 hex socket button head screw	32	1	24261	Wheel spacer
13	1	13643	TBHC M8x20 ZN screw	33	1	24262	Compression washer
14	2	13645	TBHC M10x20 ZN screw	34	1	24263	Support bearing
15	2	13647	M5x16 countersunk Allen screw	35	1	24264	0.37 kW single-phase motor brake
16	2	13658	Ø10 LL washer	36	1	24266	Motorbox SE drum
17	1	13684	FC 6x6x18 key	37	1	13226	FC 5x5x24 key
18	4	13686	M6x12 hex socket button head screw	38	1	24269	Intermediate shaft
19	1	22925	Drum shaft	39	1		SE limit switch
20	1	22931	Cover	40	1	56278	Bearing

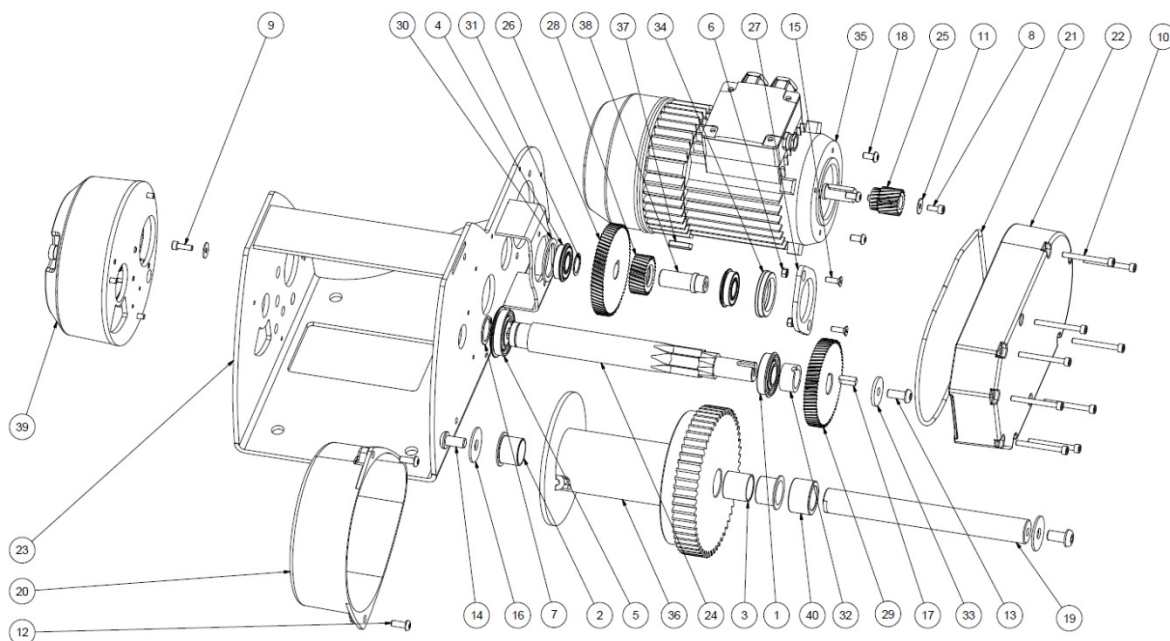



**MOTORBOX 300 kg BT**

Art.	Qty	Part number	Description	Art.	Qty	Part number	Description
1	1	2510	Bearing 6004 2RS NR	25	1	24254	18-tooth sprocket wheel
2	2	2776	Bushing QFM 2528-21	26	1	24255	71-tooth wheel
3	1	2889	Bushing QSM 2528-25	27	1	24256	Reinforcing metal closure plate
4	2	2964	Bearing 6003 2RS RN	28	1	24267	29-tooth sprocket wheel
5	1	3970	Bearing 6005 2RS RN	29	1	24268	69-tooth wheel
6	6	13009	Nut M5	30	1	24259	Bearing spacer
7	1	13047	Ext. ring 25x1.2	31	1	24260	Stop washer
8	8	13122	Screw CHC M5x12	32	1	24261	Wheel spacer
9	1	13123	Screw CHC M5x16	33	1	24262	Clamping washer
10	7	13129	Screw CHC M5x50	34	1	24263	Support bearing
11	2	13207	Washer LU 5	35	1	24264	0.37 kW single-phase motor break
12	2	13640	Screw_TBHC M6x16	36	1	24266	Drum
13	1	13643	Screw_TBHC M8x20 ZN	37	1	13226	Pin FC 5x5x24
14	2	13645	Screw_TBHC M10x20 ZN	38	1	24269	Intermediate shaft
15	2	13647	Screw TFHc M5x16	39	1		SE limit switch
16	2	13658	Washer LL Ø10	40	1	56278	Spacer
17	1	13684	Pin FC 6x6x18	41	1	2014	Small charge LV
18	4	13686	Screw_TBHC M6x12	42	4	2405	Cable gland M16 black
19	1	22925	Drum shaft	43	8	13208	Washer MU Ø5
20	1	22931	Cover	44	2	13270	Screw CHC M5x55
21	1	23777	Foam gasket	45	6	13271	Support CI 8mm
22	1	24250	Reducer cover	46	1	13701	Screw TBHC M5x10
23	1	24251	Motorbox Frame	47	1	24749	Casing
24	1	24253	8-tooth pinion shaft	48	1	64140	Casing bracing plate

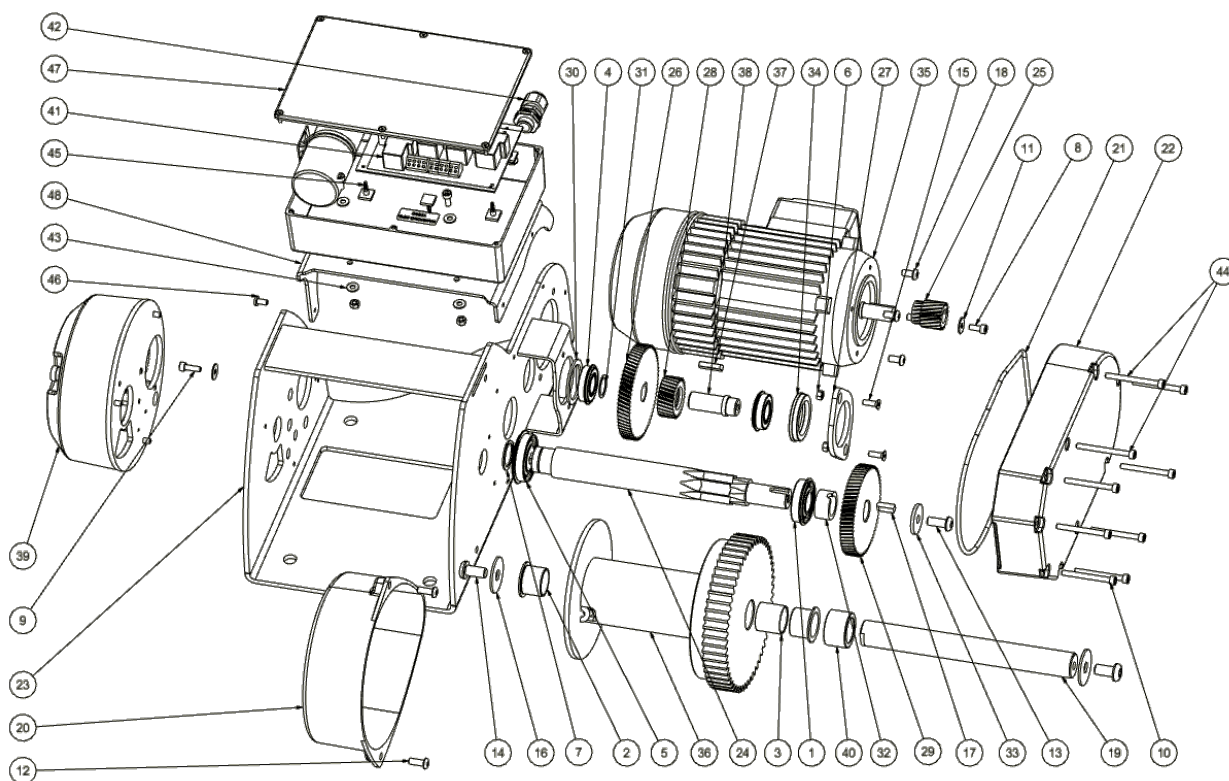



**MOTORBOX 500 kg CD**

Art.	Qty	Part number	Description	Art.	Qty	Part number	Description
1	1	2510	6004 2RS bearing	21	1	23777	Joint foam
2	2	2776	QFM 2528-21 ring	22	1	24250	Reduction gear cover
3	1	2889	QSM 2528-25 ring	23	1	24251	Motorbox frame
4	2	2964	6003 2RS RN bearing	24	1	24253	8-tooth pinion shaft
5	1	3970	6005 2RS RN bearing	25	1	24254	M1.25 18-tooth sprocket wheel
6	2	13009	M5 nut	26	1	24255	M1.25 71-tooth wheel
7	1	13047	25x1.2 ext. retaining ring	27	1	24256	Reinforcing metal closure plate
8	4	13122	M5x12 CHC screw	28	1	24257	M1.25 19-tooth sprocket wheel
9	1	13123	M5x16 CHC screw	29	1	24258	M1.25 79-tooth wheel
10	9	13129	M5x50 CHC screw	30	1	24259	Bearing spacer
11	2	13207	LU 5 washer	31	1	24260	Set ring
12	2	13640	M6x16 hex socket button head screw	32	1	24261	Wheel spacer
13	1	13643	TBHC M8x20 ZN screw	33	1	24262	Compression washer
14	2	13645	TBHC M10x20 ZN screw	34	1	24263	Support bearing
15	2	13647	M5x16 countersunk Allen screw	35	1	24264	0.37 kW single-phase motor brake
16	2	13658	Ø10 LL washer	36	1	24266	Motorbox SE drum
17	1	13684	FC 6x6x18 key	37	1	13119	FC 5x5x10 key
18	4	13686	M6x12 hex socket button head screw	38	1		SE limit switch
19	1	22925	Drum shaft	39	1	56278	Bearing
20	1	22931	Cover				

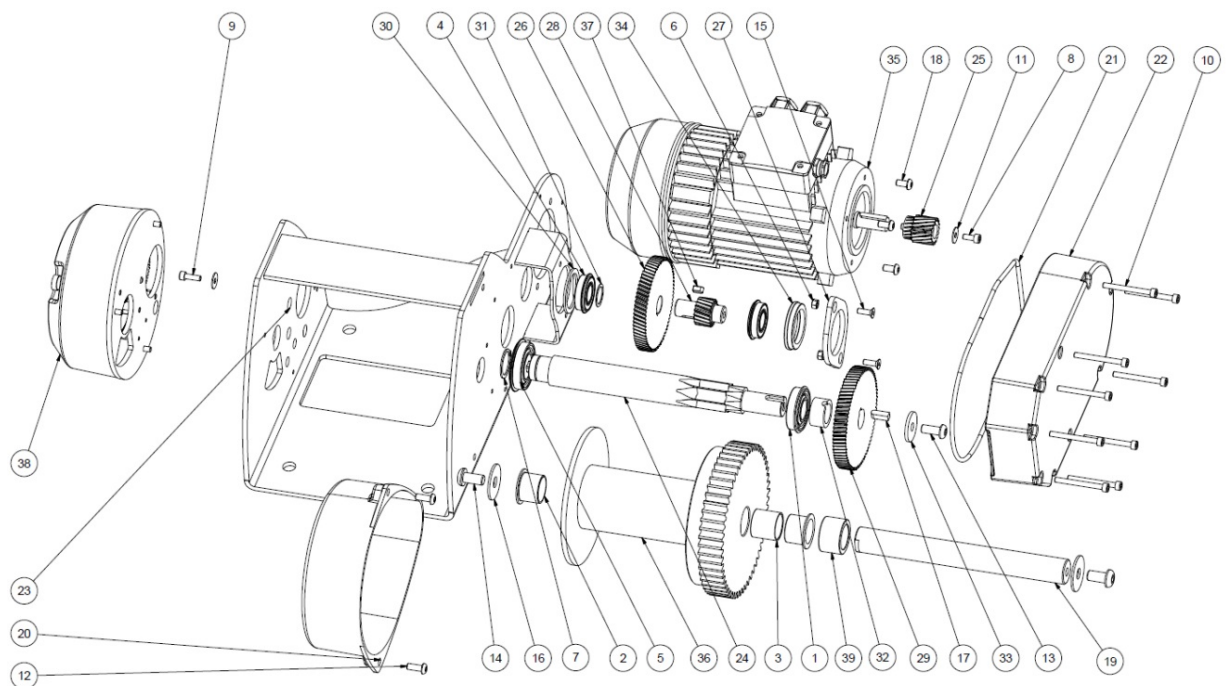

**MOTORBOX 500 kg BT**

Part	Qty	Part No.	Description	Part	Qty	Part No.	Description
1	1	2510	Bearing 6004 2RS NR	25	1	24254	18-tooth sprocket wheel
2	2	2776	Bushing QFM 2528-21	26	1	24255	71-tooth wheel
3	1	2889	Bushing QSM 2528-25	27	1	24256	Reinforcing metal closure plate
4	2	2964	Bearing 6003 2RS RN	28	1	24257	19-tooth sprocket wheel
5	1	3970	Bearing 6005 2RS RN	29	1	24258	79-tooth wheel
6	6	13009	Nut M5	30	1	24259	Bearing spacer
7	1	13047	Ext. ring 25x1.2	31	1	24260	Stop washer
8	8	13122	Screw CHC M5x12	32	1	24261	Wheel spacer
9	1	13123	Screw CHC M5x16	33	1	24262	Clamping washer
10	7	13129	Screw CHC M5x50	34	1	24263	Support bearing
11	2	13207	Washer LU 5	35	1	24264	0.37 kW single-phase motor break
12	2	13640	Screw_TBHC M6x16	36	1	24266	Drum
13	1	13643	Screw_TBHC M8x20 ZN	37	1	13119	Pin FC 5x5x10
14	2	13645	Screw_TBHC M10x20 ZN	38	1		SE limit switch
15	2	13647	Screw TFHc M5x16	39	1	56278	Spacer
16	2	13658	Washer LL Ø10	41	1	2014	Small charge LV
17	1	13684	Pin FC 6x6x18	42	4	2405	Cable gland M16 black
18	4	13686	Screw_TBHC M6x12	43	8	13208	Washer MU Ø5
19	1	22925	Drum shaft	44	2	13270	Screw CHC M5x55
20	1	22931	Cover	45	6	13271	Support CI 8mm
21	1	23777	Foam gasket	46	1	13701	Screw TBHC M5x10
22	1	24250	Reducer cover	47	1	24749	Casing
23	1	24251	Motorbox Frame	48	1	64140	Casing bracing plate
24	1	24253	8-tooth pinion shaft				

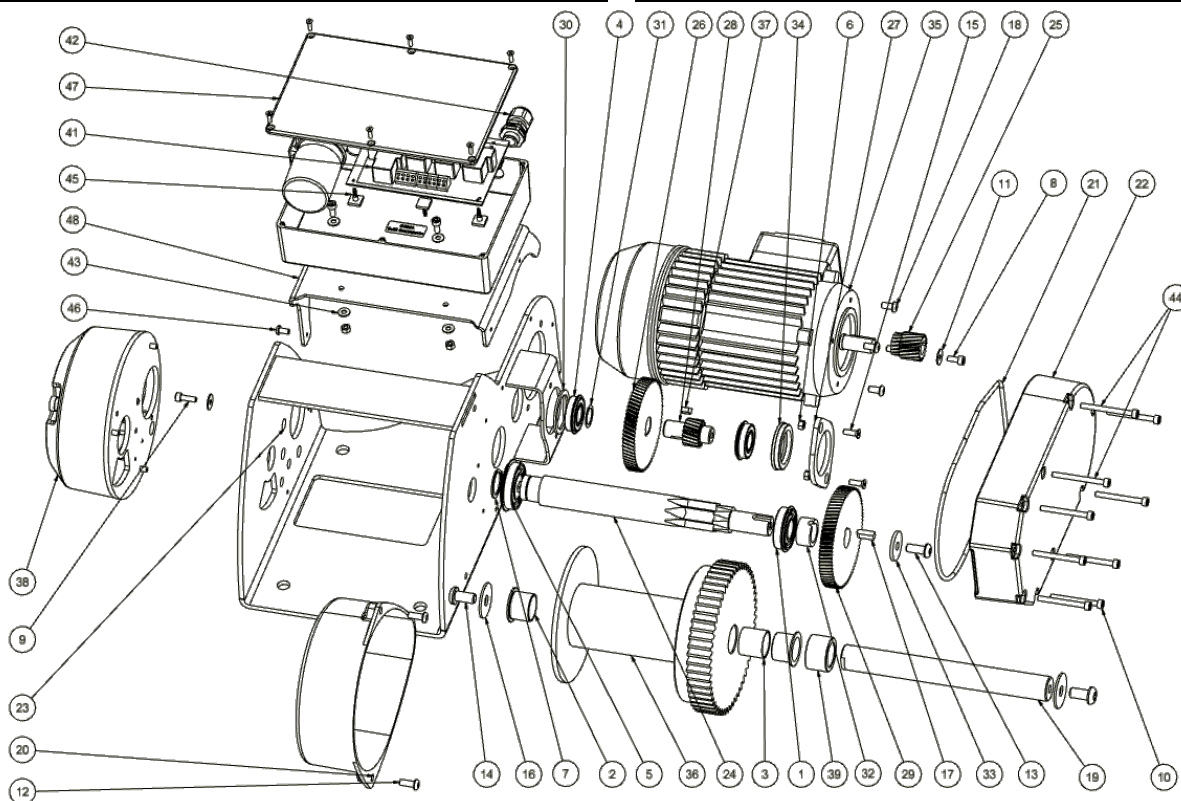

# B – Electrical diagram

## Motorbox 150, 300 and 500 kg - Direct control with limit switches

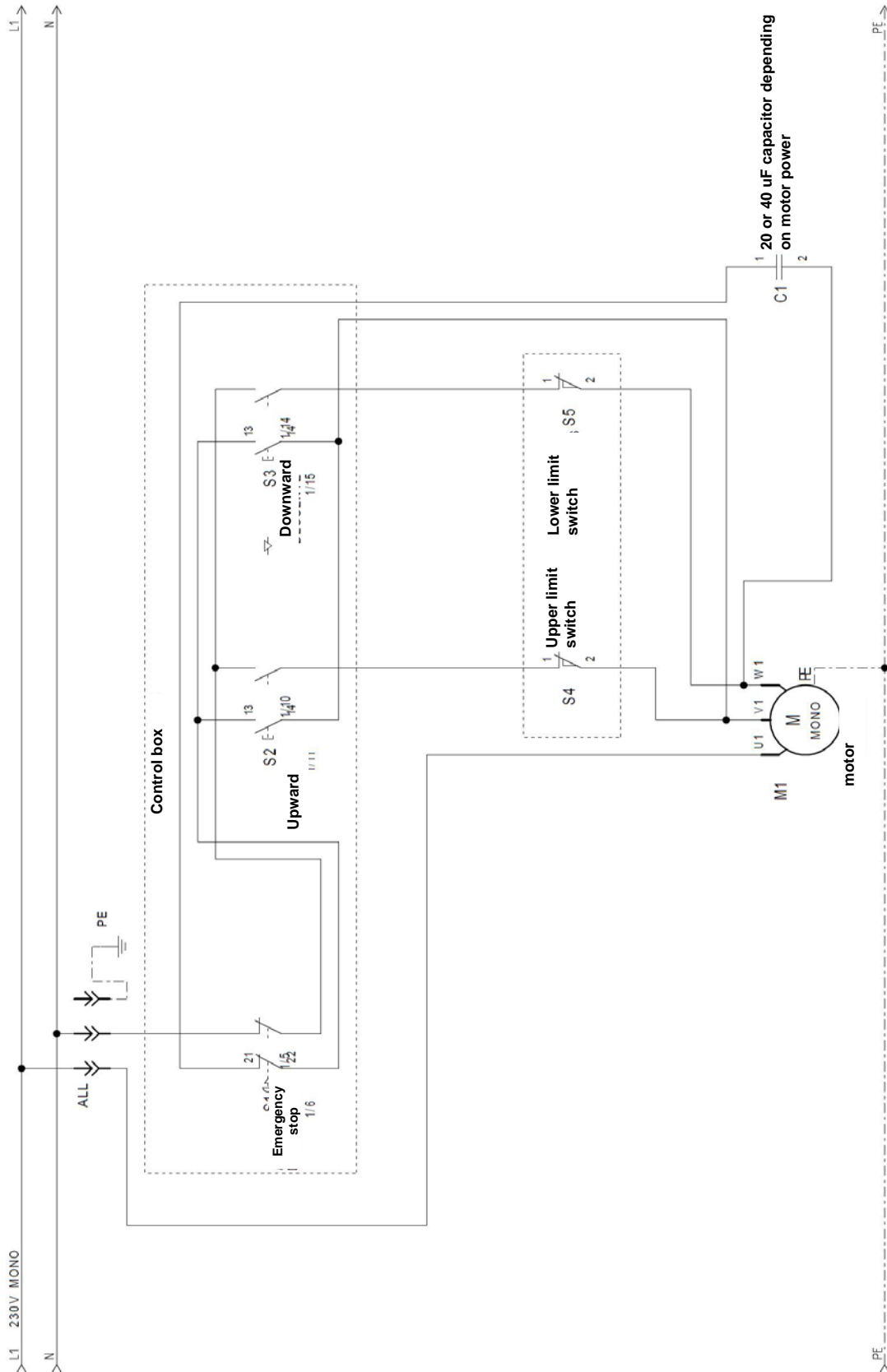

**Motorbox 150, 300 and 500 kg - Low voltage control with limit switches**

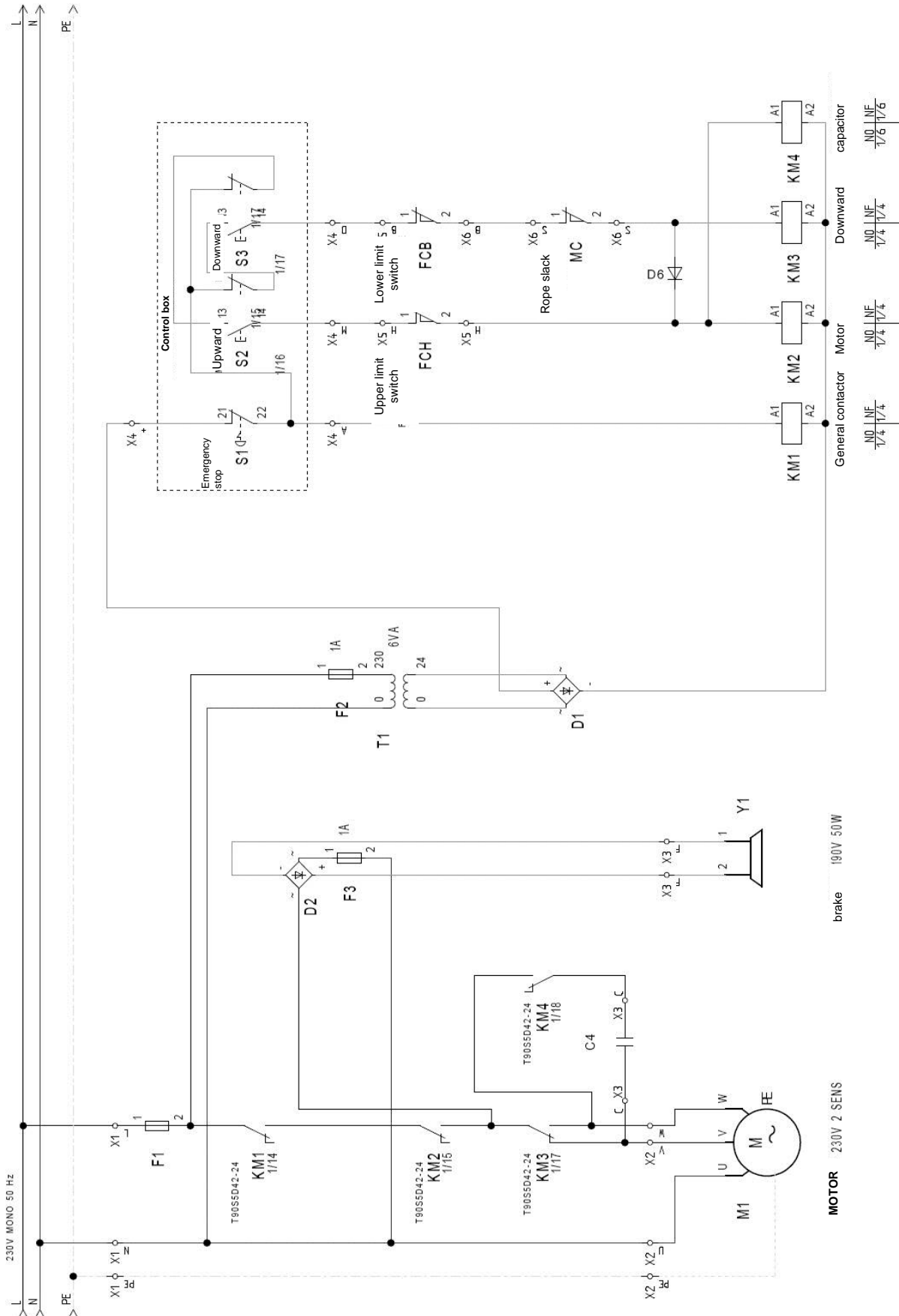

## C - Limit switch adjustment.

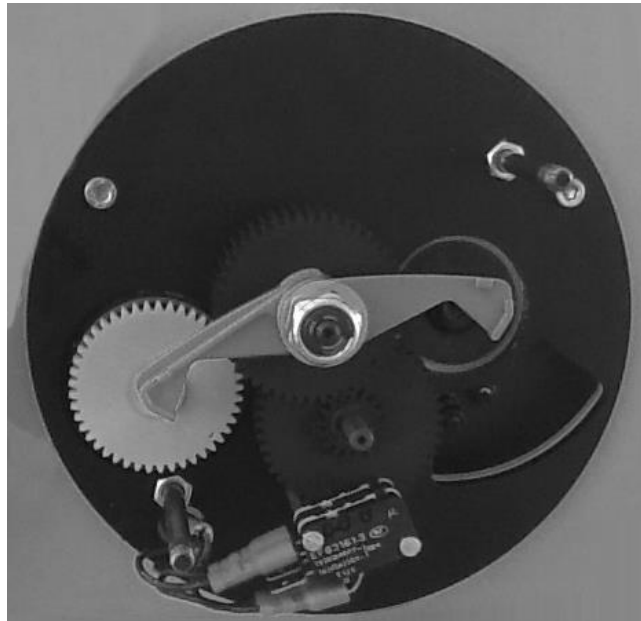

1) Lift the load to the top point and identify the lever (A or B) that is nearest the stop (S).

2) Push this lever (A or B) onto the stop (S)

3) Lower the load to the bottom point.

4) Push the second lever (A or B) onto the stop (S)

---

**1) Lift the load up to the highest required limit and find the lever moving towards the finger stop.**

**2) Place this lever (A or B) on the finger stop to fix the top limit switch.**

**3) Lower the load down to its lower level.**

**4) Place the second lever A or B on the finger stop to fix the bottom limit switch**

**D** – Maintenance booklet.

The English version of the maintenance booklet for our lifting winches can be downloaded from our website [www.huchez.fr/uk](http://www.huchez.fr/uk) under the heading "After sales services".

Date	Person In charge Company Name		Nature of the operation	References of replaced parts	Frequency if appropriate	Signature

Huchez© 2012