

Hauling winch for 4 t barges

THB

Instruction manual

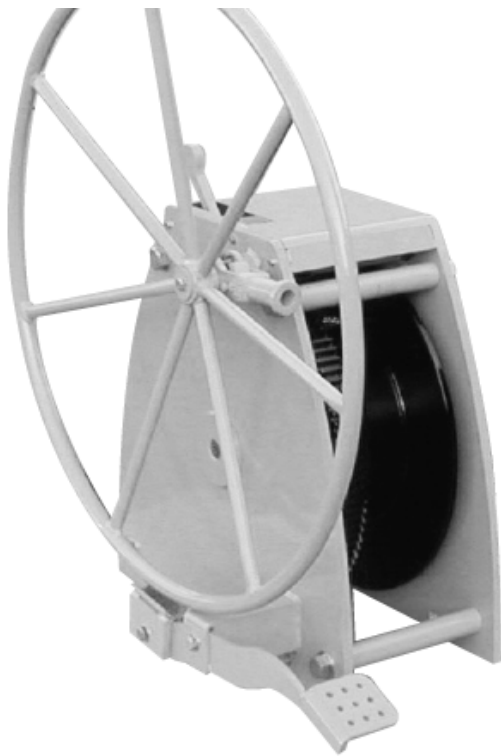

14.351.11

Contents

1 – General warning	2
2 – Presentation of appliances	2
3 – Before use	3
4 – Maintenance – Statutory, compulsory checks by the user.....	4
5 – Prohibitions for use	5
6 – User precautions	5
7 – Putting out of operation	5

1 – General warning

- Before using this winch, with safety of use of the equipment and efficiency in mind, it is vital for you to become familiar with this instruction manual and to comply with all the recommendations.
- This instruction manual must be kept available to all operators. The manufacturer shall provide additional copies on simple request.
- The THB winches are designed **ONLY** to carry out **pulling** (or holding) operations **and not for lifting**. Please make sure the operator is qualified to carry out the operation in the conditions laid down in this manual in order to respect the safety of persons and the environments.
- Never use this winch with a load exceeding the maximum working load specified.
- Before each use, the operator shall check the correct condition of appliance, its rope, hook, marking and shoring.
- The manufacturer declines all responsibility for consequences due to the use or installation of appliances not provided in this manual, together with the consequences of dismantling, alterations or replacement of original parts or components by parts or components of other sources without its written agreement.

2 – Presentation of appliances

THB winches are manual **pulling** winches built in accordance with the standards and recommendations in force for anchorage of barges together for river sailing or mooring at dock.

THB : geared winches, 4 tons pulling load (10 tons holding load).

2.1. Build

- Very rugged mechanical construction
- Capacity of up to 4 tons pulling – 10 tons holding
- Steel chassis and drum
- Spurgears, high tensile steel
- Drum and shafts mounted on self-lubricated bearings
- Operated by right of left wheel
- Retaining ratchet
- Lever-operated locking ratchet
- Pedal brake acting directly on hand wheel

2.2. Dimensions

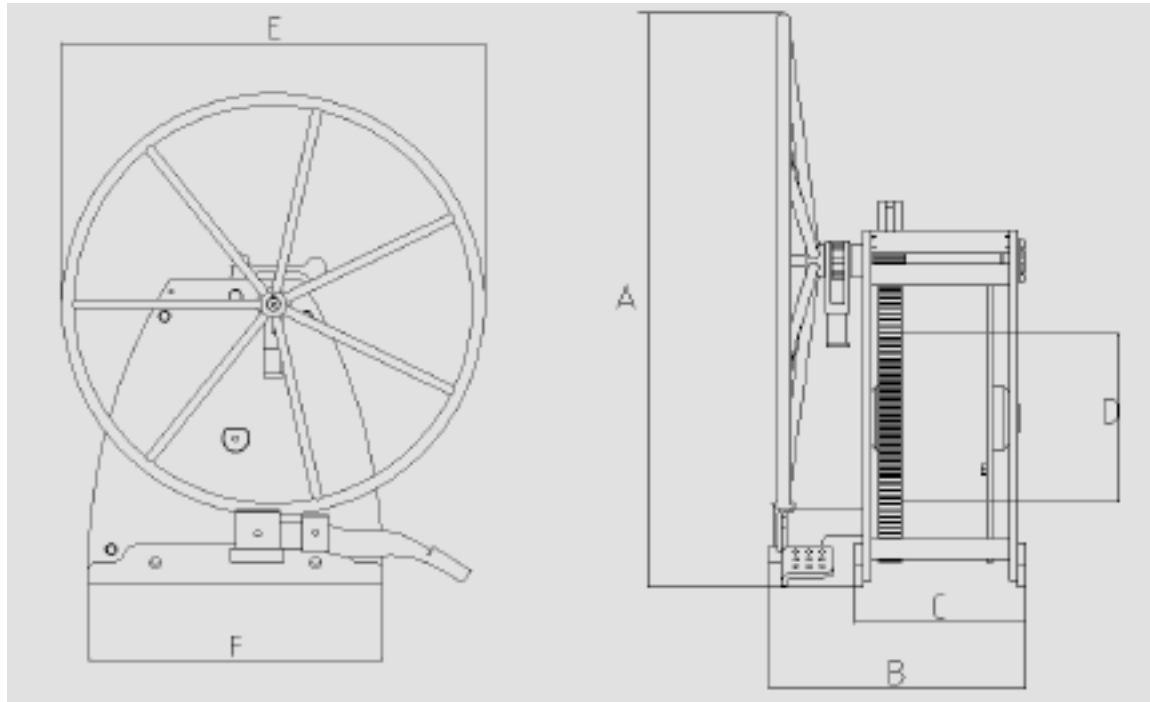

Capacity kg	A	B	C	Ø D	E	F
4000	1100	495	326	324	950	660

Capacity kg	Ø wire rope mm	Capacity drum m	Travel per handwheel revolution mm	Weight kg
4000	16	46	150	250

2.3. Accessories

THB winches can be delivered with wire rope and accessories. Concerning the wire ropes, diameters and drum capacities indicated above are corresponding to non-rotating steel ropes (18 x 7) which can be used considering the low rate of use and low operating speed of these winches. If the device you have purchased does not fall in these considerations, you should be to equip it with a steel cable standard (6 x 19). Coefficient 3.

3 – Before use

Verify the following's :

- Cleaning and greasing have been made correctly
- Wire rope is in good condition, strongly attached to the drum and with minimum 3 free spools. The wire rope must be adapted to the utilisation of the winch.
- The ratchet is free on his axle
- The brake strip is clean, and well positioned on his drum
- The fixation of the winch is proportionally calculated with nominal force
- The frame is not bend by a non flat basement
- The force on the rope is not over the winch capacity, especially in case of multi-fall use.

CHECK

- Men's position on handle : operation must be easy to do, and without risk or to hurt
- Man's position on brake : he must be very stable, and see the load and the operation leader
- The wire rope winding must be correct in order the ratchet keeps the load

CHECK the speed lever and the ratchet position

4 – Maintenance –Statutory, compulsory checks by the user

Regularly and before each use : CHECK THE CONDITION OF THE ROPE, HOOK AND SAFETY CATCH.

If the rope and hook are not supplied with the appliance by the manufacturer, check the rope and hook used guarantee a degree of safety corresponding to coefficient 3.

Periodically check the correct behaviour of the brake : (static texts : rated load + 50%).

A periodic maintenance check is required once a year.

CHECK :

- Gear's condition
- Brake efficiency
- Wire rope wear
- Ratchet deformation
- Play in collars

CLEANING-GREASSING

With a stable viscosity grease

- Wire rope on his length (depending on wire rope type)
- Gears
- Ratchet axle

TEST

- After longtime without service
- After major repairing Ratchet axle
- After intensive or anormal use

5 – Prohibitions for use

Before any use, make sure there is no risk of overloading due to : adherence to floor, suction, jamming, etc.

You are to be warned against any of the following improper uses or handling operations :

It is prohibited to :

- pull loads exceeding the rated load specified on the plate of the appliance ;
- unwind the drum completely (keep 2 to 3 extra- turns) ;
- pull sideways ;

- swing the load ;
- use ropes with a diameter and texture not complying with the specifications of this manual (coefficient 3) ;
- use damaged or spliced ropes ;
- use hooks without catches, not suitable for the loads specified on the appliance or in bad condition ;
- insert objects into the moving parts ;
- allow the load to fall freely ;
- motorize the appliances ;
- use the rope of the appliance as a sling ;
- use handles different from the original ones ;
- use the appliances for operations different from those they are designed for ;
- use parts or components different from the manufacturer's original parts or components ;
- reeve, positioning the fixed point on the winch.

6 – User precautions

- The operating temperature must be comprised between -10°C and +50°C.
- These winches must be operated frequently, even with no load, especially when used in harsh environments. Extended inactivity can risk damaging the braking system (brake jammed).
- You are strongly advised not to handle the cable without wearing protective gloves.

7 – Putting out of operation

When the equipment is in state of decay likely to create risks, the user is obliged to do away with this material i.e. : put it out of operation, dismantle it if required.