

## INDUSTRIA 5 t, FEM/ISO 3m/M6, t, tambour long - 7 m/min, low voltage control



Electric winch 5000 kg. Range of electric winches initially designed to satisfy the needs of the industrial sector.

Use:

- All lifting or pulling/hauling applications
- Industry
- Building and public works
- Integration into cranes...
- Pulling/hauling of heavy loads
- Conveyor belt tensioning
- Opening hatches
- Lifting sluice gates
- Stage industry...

Comply with Machines Directive 2006/42/EC and standard NF 14492-1.

### Technical properties

- Robust and highly compact.
- Vertical mounting possible.
- 230/400 V - 50 Hz three-phase brake motor. IP 55 Protection. Other voltage or frequencies optional. P = 9,2 kW.
- Motor position: horizontal (possibility of vertical on request).
- The low voltage control protects the user from electrical risks. It makes it possible to operate a wide range of options: from limit switch to radio control, including a load limiter and a rope slack switch...
- The tie-rods are mobile according to the rope outlet.
- Anti-escape system for the rope.
- FEM/ISO 3m/M6 classification.
- Model with long drum.
- Reduced space between the tie-rod and the drum.
- Rope-press roller and rope slack switch incorporated under the upper tie-rod (incorporation into the tie-rod as an option).
- Reliable electric and electronic components.
- Limit switch obligatory when lifting and from 1000 kg, load limiter.
- Sealed electrical unit on the winch consisting on: contactors, 24 V transformers, thermal circuit breaker, disconnectable pendant control with 3 m of cable.
- Reduced-maintenance planetary reduction gears.
- Numerous rope outlet possibilities.
- Options available: rope-press roller, grooved drum, specific paint, drum length on request, phases detector, lower chassis, timer, tarpauline cover...

**Technical characteristics of INDUSTRIA 5 t, FEM/ISO 3m/M6, t, tambour long - 7 m/min, low voltage control with 1 speed**

References	INDUS3M_L_5T_07
Capacity 1st layer kg	6250
Capacity top layer kg	5000
Nb of layers	3
Wire rope cap. 1st layer m	35
Max. rope capacity m	124
Wire rope Ø mm	18
Fixed speed 1st layer m/min	6
Fixed speed top layer m/min	7,5
FEM	3m
Motor kW	9,2
Power	3Ph-230/400V
Weight (without wire rope) kg	560

**Dimensions**

References	INDUS3M_L_5T_07
A mm	1470
B mm	520
C mm	665
D mm	Ø 355,6
E mm	600
F mm	850
G mm	420
H mm	Ø 22
I mm	50
J mm	30
K mm	300
M mm	210
N mm	1190
O mm	795

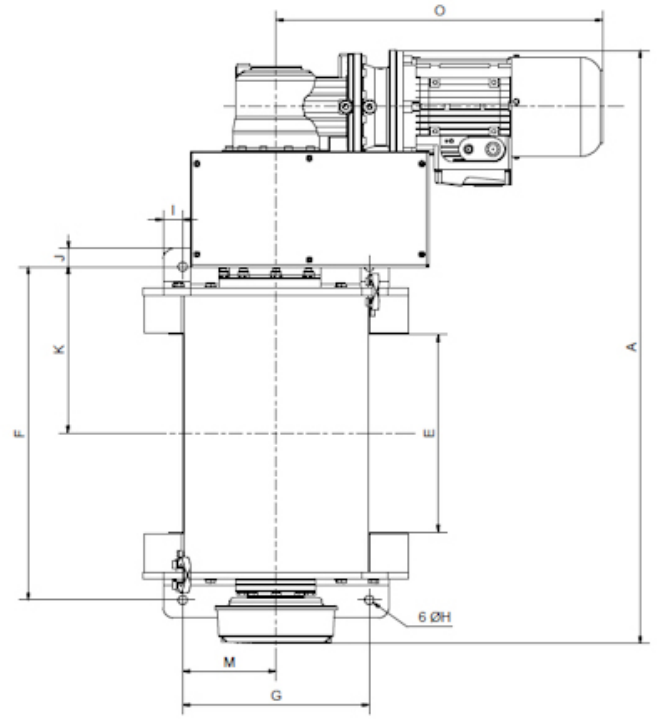

## Technical characteristics of the other models of the range



### HUCHEZ's advice

These compact winches satisfy the needs of the industrial sector. Mobile tie-rods according to the rope outlet.  
Numerous options available.



HUCHEZ  
4, rue Michel HAMMID  
60420 FERRIERES – France  
☎ +33 (0) 3 44 51 11 33  
🌐 [www.huchez.com](http://www.huchez.com)  
✉ [contact@huchez.fr](mailto:contact@huchez.fr)



SERVICE CLIENTS  
ATENCIO AL CLIENTE  
KUNDENSERVICE



Pour en savoir plus, n'hésitez pas à nous contacter!  
To know more, please contact us!  
Para más información, póngase en contacto con nosotros!  
Für weitere Informationen können Sie sich gerne an uns wenden!